



IOT-Based Fiber Optic Condition Monitoring

Varshigashree M¹, Shakthi Oviya P², Jayanthimani V³, Siva Parvathy M⁴, Mariammal K⁵, Vinotheni M S⁶
^{1,2,3,4}UG Scholar, Dept. of ECE, Madras Institute of Technology, Anna University, Chennai, India.

⁵Associate professor, Dept. of ECE, Madras Institute of Technology, Anna University, Chennai, India.

⁶Teaching fellow, Dept. of ECE, Madras Institute of Technology, Anna University, Chennai, India.

Emails: varshigashree6904@gmail.com¹, shakthioviya2005@gmail.com², jayanthi152001@gmail.com³, gayathrimarisamy27@gmail.com⁴, mariammal@annauniv.edu⁵, vinotheni.malar@gmail.com⁶

Abstract

The IoT-Based Fiber Optic Condition Monitoring System is designed to continuously observe the health, performance, and environmental conditions on optical fiber link. Optical fiber communication, despite its significant advantages such as high bandwidth and low attenuation, remains highly vulnerable to physical disturbances, bending, vibrations, and excessive temperature variations. These factors affect signal intensity and may lead to degradation or complete communication failure. To address this, the proposed system integrates low-cost sensors including DHT22 for temperature monitoring, an LDR for optical intensity measurement, and a vibration sensor for mechanical disturbance detection. The ESP32 microcontroller serves as the core of the system, collecting sensor data and transmitting it using the lightweight MQTT protocol to a subscriber node. Real-time values are displayed on an OLED screen, and the fiber condition is visually indicated using LEDs categorized as Line OK, Medium Risk, and Fault Detected. Experimental results confirm that the system accurately detects early warning signs of fiber disturbance and environmental stress. This IoT-based approach provides a scalable, low-cost, and reliable alternative to conventional fiber-monitoring techniques, enabling proactive maintenance and enhancing communication reliability.

Keywords: Condition Monitoring; DHT22; LDR; MQTT; OLED; Optical fiber.

1. Introduction

Optical fiber communication forms the backbone of modern telecommunication systems, enabling high-speed, high-capacity data transmission over long distances with minimal loss. Its advantages, including low attenuation, immunity to electromagnetic interference, and high bandwidth, make it the preferred medium for broadband, telecommunication, and industrial networks. However, optical fibers are highly sensitive to environmental and mechanical factors such as excessive temperature, vibration, bending, and strain, which can lead to increased attenuation, signal distortion, or even fiber breakage. Traditional fault detection techniques like Optical Time Domain Reflectometry (OTDR) offer precision but are costly, power-intensive, and not suitable for real-time monitoring [1][2]. Hence, the integration of Internet of Things (IoT) technologies provides a promising

alternative for continuous, low-cost, and intelligent condition monitoring of fiber links [3][4].

1.1. Context and Literature

Over the years, several fiber monitoring approaches have evolved from distributed sensing to IoT-based real-time observation. Horiguchi et al. [1] pioneered Brillouin-based distributed sensing to measure strain and temperature, while Kersey et al. [2] introduced fiber Bragg grating (FBG) sensors for localized strain detection. Later, low-cost alternatives such as photodiode and LDR-based optical systems were developed to correlate optical loss with fiber deformation [3][4]. With the rapid rise of IoT, researchers began using microcontrollers like ESP8266 and ESP32 to monitor environmental and optical parameters via cloud platforms [5][6]. These IoT-based systems enhanced real-time fault detection, scalability, and remote access, marking a

major step toward smart optical monitoring.

1.2. Problem Definition and Objectives

With the increasing dependence on high-speed data transmission, the reliability of optical fiber networks has become a critical factor for modern communication systems. Optical fibers, although efficient, are vulnerable to various types of faults such as fiber cuts, bending losses, connector issues, and environmental influences. Traditional fault detection methods are often manual, time-consuming, and unable to provide real-time feedback. Therefore, smart optical fiber monitoring systems are essential to ensure continuous network availability and preventive maintenance. These systems integrate advanced sensing, automation, and data analytics to monitor network performance dynamically,

minimizing downtime and operational costs while enhancing service quality and reliability [1].

2. Method

The proposed system integrates IoT technology with traditional optical fiber infrastructure to enable real-time monitoring of fiber health and performance. The design emphasizes modularity, allowing flexible hardware configuration and simple software scalability. It involves both hardware and software components working together to detect, transmit, and display variations in optical intensity, vibration, and temperature. The overall system operation is divided into two main parts: system design and principle of operation, ensuring a clear understanding of both implementation and functionality [5].

Table 1 Experimental input parameters for Publisher and Subscriber

Sensor	Parameter Monitored	Output	Function
DHT22	Temperature	°C	Detects temperature fluctuations
LDR	Light Intensity	Analog	Measures fiber signal strength
Vibration Sensor	Mechanical Disturbance	Digital	Detects fiber vibration or fault
OLED Display	Visual Output	Text	Displays real-time condition
ESP32	Controller	Wi-Fi	Publishes/subscribes data via MQTT

Table 1 displays the list of sensors used in the proposed system along with their specifications and functional roles. It includes the DHT22 for temperature measurement, LDR for optical intensity detection, and the vibration sensor for monitoring mechanical disturbances, forming the core sensing components of the monitoring setup.

2.1. Tables

The proposed setup comprises two ESP32 microcontrollers, configured as publisher and subscriber nodes. The publisher node is responsible for collecting real-time environmental and mechanical data through three key sensors — DHT22 for temperature, LDR for optical intensity, and a vibration sensor for mechanical disturbances. These

sensed parameters are transmitted wirelessly to the MQTT broker, which acts as a message mediator between both nodes [6][7]. The subscriber node receives the transmitted data, interprets it, and displays the current optical fiber condition on an OLED display while also activating corresponding LED indicators representing states such as Line OK, Medium Risk, and Fault Detected. The software design employs MicroPython executed within the Wokwi simulation environment, ensuring compatibility, scalability, and testing efficiency. The implementation utilizes essential libraries — umqtt.simple for MQTT communication, ssd1306 for OLED interfacing, and dht for temperature sensing. The modular coding approach enhances readability,

debugging, and system performance. Together, these hardware and software integrations ensure a real-time, wireless, and energy-efficient monitoring system [8].

2.2. Principle of Operation

Upon initialization, the publisher node establishes a Wi-Fi connection and activates its sensor suite. The DHT22 measures ambient temperature, the LDR monitors optical signal intensity variations, and the vibration sensor detects shocks or mechanical stress on the optical cable [9]. Sensor readings are continuously packaged and transmitted via MQTT protocol to the subscriber node. The subscriber evaluates these readings against pre-set thresholds to determine the fiber's operational status. If a parameter deviates beyond acceptable limits, an alert is triggered — an LED indicator changes color and the OLED display presents diagnostic messages such as “Medium Risk” or “Fault Detected.” This mechanism enables real-time condition awareness, promoting preventive maintenance and reducing downtime. Figure 1 illustrates the working principle of the IoT-based smart optical fiber monitoring system.

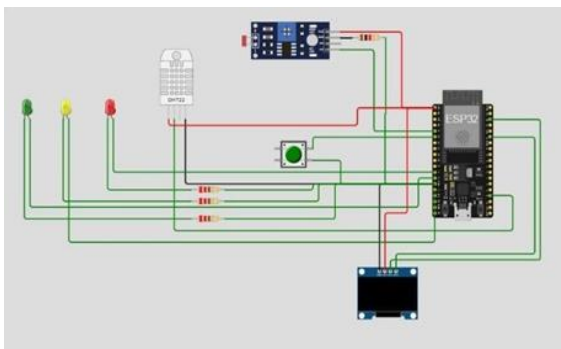

Figure 1 Hardware Architecture

3. Results and Discussion

3.1. Results

The developed system successfully monitored and transmitted temperature, vibration, and optical intensity data over MQTT. The OLED display provided real-time visualization, and the LED indicators effectively categorized fiber health conditions. The system maintained consistent communication between publisher and subscriber nodes with minimal latency [10] [11].

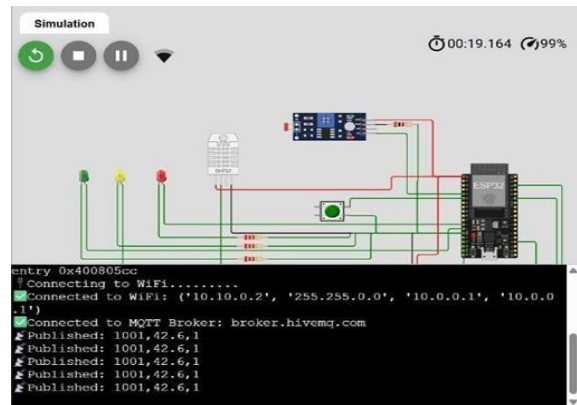

Figure 2 MQTT Publisher

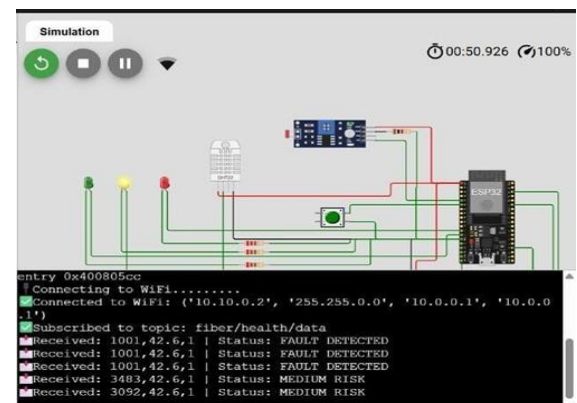

Figure 3 MQTT Subscriber

In conclusion, Figures 2 and 3 demonstrate the successful implementation of an MQTT-based communication system using ESP32 microcontrollers. The publisher node effectively gathers sensor data and transmits it to the MQTT broker, while the subscriber node reliably receives and processes the published information in real time. This setup verifies efficient, low-latency data exchange between devices over Wi-Fi, showcasing the practicality of MQTT for Internet of Things (IoT) applications. The experiment highlights the robustness, scalability, and simplicity of MQTT as a lightweight protocol for sensor data transmission, making it ideal for smart monitoring and automation systems.

3.2. Discussion

The results confirm the feasibility of using IoT for continuous optical fiber monitoring. Compared to traditional Optical Time-Domain Reflectometer (OTDR)-based methods, the proposed model offers a significant reduction in cost, enhanced scalability,



and simplified deployment. OTDR systems, though accurate, are typically expensive, require complex calibration, and are not well-suited for continuous real-time monitoring over distributed networks. In contrast, the IoT-based approach utilizes low-cost sensors and ESP32 microcontrollers integrated with MQTT communication to enable an efficient, continuous monitoring system. The system continuously measures optical power variations in the fiber and correlates them with environmental parameters such as temperature, humidity, and vibration, providing valuable insights into potential fiber degradation or external disturbances. The use of multiple sensors in the proposed model enhances detection accuracy by cross-verifying optical intensity losses with other environmental changes. This multi-sensor correlation enables early detection of faults such as fiber bending, microbending losses, or external impacts, which might otherwise go unnoticed in traditional monitoring systems. The data collected is transmitted using the MQTT protocol, which ensures low-latency and reliable communication between publisher and subscriber nodes. MQTT's lightweight structure makes it highly suitable for IoT applications where bandwidth and power efficiency are critical. Furthermore, the scalability of this model allows multiple sensing nodes to be deployed across a wide fiber network, all communicating through a centralized MQTT broker. This distributed monitoring framework can be easily extended or modified depending on the network's scale and complexity. The results demonstrate that this approach not only provides real-time monitoring but also facilitates predictive maintenance by analyzing long-term data trends. Therefore, the proposed IoT-based optical fiber monitoring system represents a cost-effective, energy-efficient, and adaptable alternative to conventional methods, offering a practical solution for industrial, telecommunication, and infrastructure health monitoring applications [12] [13] [14] [15].

Conclusion

The IoT-Based Fiber Optic Condition Monitoring System provides a smart, low-cost, and real-time solution for observing fiber link health. By integrating DHT22, LDR, and vibration sensors with

the ESP32 platform, the system can detect early-stage fiber degradation. MQTT ensures efficient data transfer between nodes, while OLED and LED indicators enable easy condition assessment. The approach supports proactive maintenance and improves communication reliability.

Acknowledgement

The authors express sincere gratitude to the Department of Electronics Engineering, Madras Institute of Technology, Anna University, for providing technical guidance and laboratory facilities. The authors also thank the faculty mentors for their valuable inputs and support throughout the project.

References

- [1]. Horiguchi, T., Kurashima, K., & Tateda, M. (1995). Distributed measurement of strain and temperature in optical fibers using Brillouin scattering. *IEEE Journal of Lightwave Technology*, 13(7), 1296–1302.
- [2]. Kersey, A. D., Davis, M. A., & Patrick, H. J. (1997). Fiber grating sensors. *Journal of Lightwave Technology*, 15(8), 1442–1463.
- [3]. Kumar, P., & Sharma, R. (2022). Photodiode-based optical fiber monitoring for fault detection. *IJESRT*, 9(4), 456–460.
- [4]. Patel, R., Singh, S., & Rana, P. (2023). LDR-based optical intensity sensing for fiber break detection. *IEEE ICSC*, 110–114.
- [5]. Das, A., Ghosh, R., & Banerjee, T. (2023). IoT-enabled optical fiber monitoring using Blynk cloud. *IJETAE*, 12(8), 72–78.
- [6]. Chawla, N., & Verma, S. (2022). MQTT-based IoT network for optical cable fault detection using ESP8266. *IEEE TENCON*, 2214–2219.
- [7]. Rane, K., & Mehta, A. (2022). MQTT-based smart sensor network using ESP32 for environmental applications. *IEEE Access*, 10, 15409–15416.
- [8]. Shinde, P., & Verma, R. (2023). Environmental data monitoring using ESP32 and DHT22 over MQTT. *IJIRSET*, 11(5), 3008–3014.
- [9]. Roy, R., Das, K., & Prakash, A. (2023). IoT-based multi-sensor node with OLED display



- for smart monitoring. *ICIoE*, 45–50.
- [10]. Manikandan, P., & Devi, L. (2024). Vibration and optical intensity monitoring for fiber link health detection. *IEEE Sensors Symposium*, 150–156.
- [11]. Soni, A., & Desai, V. (2023). IoT-enabled optical sensing for proactive network maintenance. *IJERT*, 12(9), 200–205.
- [12]. Pandey, N., & Chaturvedi, S. (2024). Comparative study on optical monitoring systems using IoT. *IJSER*, 15(3), 98–103.
- [13]. Basha, M., & Rao, P. (2023). Smart fault detection in fiber links using ESP32. *IEEE INDICON*, 870–875.
- [14]. Meenakshi, R., & Vignesh, T. (2024). Performance analysis of MQTT and HTTP for IoT-based monitoring. *IEEE Access*, 12, 4511–4518.
- [15]. Krishnan, A., & Bose, S. (2023). Integration of IoT with optical sensor networks for condition monitoring. *IEEE Internet of Things Journal*, 10(5), 3020–3028.