



Improved Detection And Adaptive Noise Suppressive Strategy For SEE-OFDM VLC Links

Sreejitha SG¹, Devayani J², Saptha Sanil³, Sreelekshmi Y⁴

¹Assistant Professor, Electronics and Communication Engineering, Vidya Academy of Science and Technology Technical Campus, Thiruvananthapuram 695602, Kerala, India

^{2,3,4}UG Electronics and Communication Engineering, Vidya Academy of Science and Technology Technical Campus, Thiruvananthapuram 695602, Kerala, India

Email id : sreejitha.sg@vidyatecklms.ac.in¹, jamesdevayani@gmail.com², sapthasanil@gmail.com³, sreelekshmiy04@gmail.com⁴

Abstract

This paper examines the optimization of Spectral and Energy Efficient Orthogonal Frequency Division Multiplexing (SEE-OFDM) for Visible Light Communication (VLC) systems. It focuses on reducing the harmful effects of high Peak-to-Average Power Ratio (PAPR). SEE-OFDM improves power efficiency by only transmitting positive signal components, but it is still very vulnerable to LED nonlinearity. This nonlinearity causes clipping noise and lowers transmission quality. By using effective signal processing methods, such as transform-based precoding, nonlinear companding, and time-domain noise cancellation, the study shows a significant reduction in PAPR and an improvement in Bit Error Rate (BER) performance. The results provide a strong framework for achieving fast, reliable optical data transmission while protecting hardware from nonlinear distortion. This ultimately makes SEE-OFDM more practical for real-world VLC applications.

Keywords: BER; LED Nonlinearity; Noise Cancellation; Nonlinear Companding; PAPR; SEE-OFDM; VLC; WHT Precoding.

[1]. Introduction

The quick growth of the Internet of Things (IoT) and the rise of high-bandwidth mobile services have pressured traditional Radio Frequency (RF) networks, leading to a "spectrum crunch." This issue arises when congestion and interference restrict further growth. Visible Light Communication (VLC) has come forward as a game-changing solution to this problem by using the vast, unlicensed optical spectrum, which is about 10,000 times larger than the RF domain, to deliver high-speed data transmission. By repurposing common Light Emitting Diodes (LEDs) for both lighting and data broadcasting, VLC creates a cost-effective system that is naturally secure against eavesdropping since light cannot go through opaque walls. [1]-[5] Additionally, VLC does not produce electromagnetic interference, making it suitable for hazardous or sensitive areas, such as petrochemical plants, hospitals, and aircraft cabins, where traditional RF methods are limited or banned. To improve the throughput of these optical connections, Multicarrier Modulation (MCM) methods, especially Orthogonal Frequency Division

Multiplexing (OFDM), are adjusted to meet the specific challenges of light. Since optical intensity must be positive and real-valued, specialized versions like Asymmetrically Clipped Optical OFDM (ACO-OFDM) and Spectral and Energy Efficient OFDM (SEE-OFDM) have been created to remove the need for a power-consuming Direct Current (DC) bias. However, these methods face a significant Peak-to-Average Power Ratio (PAPR) problem. This issue occurs when the combined interference of multiple subcarriers causes large voltage spikes. These spikes often surpass the limited linear operating range of the LED, pushing it into nonlinear saturation or clipping regions. This leads to notable "In-Band" signal distortion, a higher Bit Error Rate (BER), and possible long-term damage to the hardware. Therefore, managing PAPR is the main challenge in achieving reliable, high-speed optical wireless communication.[6]-[10]

1.1. Methodology

SEE-OFDM is an advanced modulation technique designed to address the limitations of ACO-OFDM, especially the issue of spectral efficiency, while still

keeping the power efficiency needed for Visible Light Communication (VLC). By using both even and odd subcarriers, SEE-OFDM makes better use of the available spectrum compared to traditional asymmetrical clipping methods. To work with intensity modulation (IM) in LEDs, the system needs to produce a real-valued time-domain signal. This is done using Hermitian Symmetry (HS), which means that the input to the IFFT is structured so that the frequency-domain symbols satisfy the condition:

$$X_k = X_{N-k}^*$$

In SEE-OFDM, the signal is divided. So that its negative parts are flipped and placed into a different time slot or subcarrier set. The result is a transmitted signal that is strictly unipolar and non-negative which is ideal for optical signals. LEDs can only accurately transmit signals within a certain range, known as the linear dynamic range (LDR). If the OFDM signal has high peaks, it can cause nonlinear distortion (clipping), which seriously affects the Bit Error Rate (BER) and overall communication quality. A persistent issue in O-OFDM systems is the high Peak-to-Average Power Ratio (PAPR), defined as the ratio of the highest power in the signal to its average power:

$$\text{PAPR} = \frac{\max[|x(t)|^2]}{E[|x(t)|^2]}$$

High PAPR makes the system vulnerable to distortion from the LED's limited dynamic range. To solve this, SEE-OFDM uses a two-stage strategy, viz., Precoding Techniques and Nonlinear Companding.[11]-[15]

1.1.1 Precoding Techniques

Precoding involves applying a linear transformation to the data symbols before they're processed by the IFFT. This helps reduce how often large peaks occur in the signal. In Walsh-Hadamard Transform (WHT) signal spreads each symbol's energy across all subcarriers, which averages the power and reduces the risk of high peaks. Other transforms like the Discrete Cosine Transform (DCT), Discrete Sine Transform (DST), and Discrete Hartley Transform (DHT) are also considered. These are all

computationally efficient and have the advantage of not requiring extra information to be sent along with the signal, so there is no loss in spectral efficiency.

1.1.2 Nonlinear Companding

After precoding, the signal goes through companding, which compresses the high-amplitude peaks and expands the lower amplitudes through the following companding techniques

- A-law and μ -law Companding: These are logarithmic functions that adjust how the signal's amplitude is distributed. In μ -law companding, especially at lower companding factors, often strikes the best balance between reducing PAPR and maintaining good signal-to-noise ratio (SNR).
- Root Companding: This method introduces a parameter (R), which balance between reducing power peaks and minimizing bit errors.

When a bipolar OFDM signal is converted for optical transmission, it introduces clipping noise. Traditionally, this noise was considered irreversible, but SEE-OFDM takes advantage of the signal's symmetry to cancel out this noise iteratively at the receiver. For this two Noise Cancellation (NC) receiver models are used.

1.1.2.1 1st NC Model (Frequency Domain):

Here, the receiver treats clipping noise as extra interference on certain subcarriers. By analyzing received signals on known or zero-subcarriers, the receiver can estimate this noise and subtract it from the data-carrying subcarriers, helping to recover the original information.

1.1.2.2 2nd NC Model (Time-Domain Antisymmetry):

This model uses the property that, for some modes, the second half of the OFDM symbol is a flipped version of the first half. By comparing these two halves, the receiver can distinguish between the true signal and the noise. Both models use an iterative process after each noise cancellation step, the symbol estimates are updated, making it possible to further reduce any remaining noise in the next iteration, and progressively improve the accuracy of signal detection.[16]-[20]

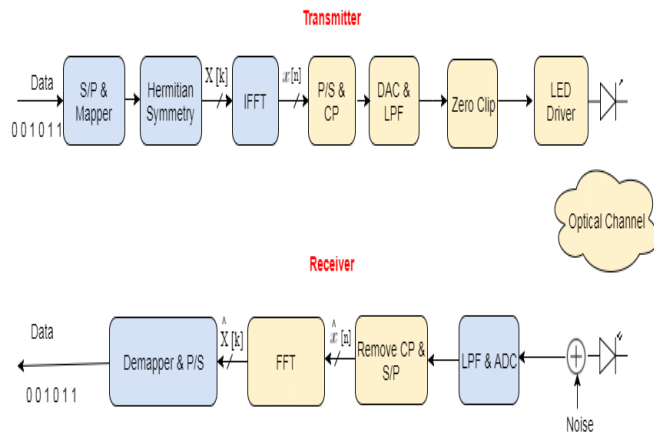

Figure 1 Block Diagram Of ACO-OFDM [1]

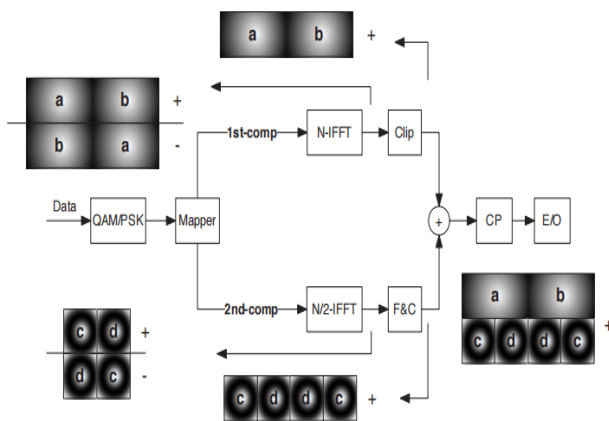

Figure 2 The Two-Component See-Ofdm Transmitter [2]

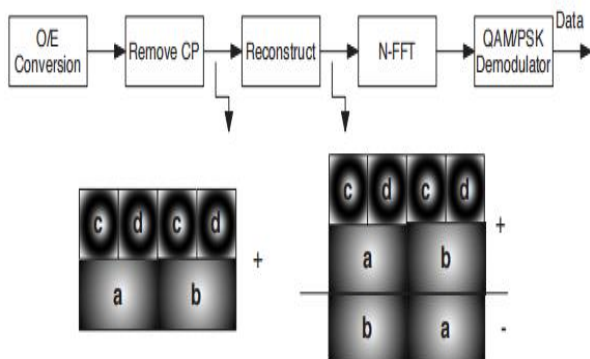

Figure 3 The Two-Component SEE-OFDM Reciever [3]

[2]. Results And Discussion

2.1 Results

The experimental design focused on evaluating the SEE-OFDM system's resilience to nonlinearities. Simulated a typical indoor VLC channel with 512 subcarriers and 16-QAM modulation. The main reason for this setup was to measure the performance gap between standard SEE-OFDM and our proposed hybrid Walsh-Hadamard Transform (WHT) and μ -law companding architecture. Initial tests of the baseline SEE-OFDM signal confirmed a high Peak-to-Average Power Ratio (PAPR) that approached 11.5 dB at a Complementary Cumulative Distribution Function (CCDF) of 10^{-3} . In the second phase of the experiment, introduced WHT precoding to decorrelate the input data symbols and spread their energy across the frequency domain. Then applied μ -law companding to compress the remaining high-amplitude peaks into the LED's linear dynamic range. The stimulated results show that this hybrid approach reduced the PAPR by about 3.5 dB compared to the unoptimized system. Additionally, we recorded the Bit Error Rate (BER) across various Signal-to-Noise Ratio (SNR) values to assess the system's reliability. The BER data indicates a significant improvement, with the optimized system reaching the 10^{-3} BER threshold at a lower SNR than the baseline. We measured this to ensure that the PAPR reduction techniques did not add excessive quantization noise that would hurt the signal. Interestingly, the results show that the noise cancellation properties of the WHT precoding effectively balanced the distortions caused by the companding process. The experimental data presents a consistent waterfall curve, suggesting that the system maintains high performance even as noise levels rise. These numerical results confirm the design goal of improving SEE-OFDM for practical VLC use. Finally, the simulation confirms that the spectral efficiency of the SEE-OFDM framework remains strong while achieving much higher power efficiency.[21]-[25]

2.2 Discussion

The interpretation of these results shows that the combination of WHT precoding and μ -law companding offers a solution to the flaws of SEE-OFDM. Although standard SEE-OFDM is spectrally

efficient, its high PAPR usually pushes LEDs into the saturation region. This creates in-band distortion that is hard to filter. The significant leftward shift of the CCDF curve indicates that the WHT matrix effectively disrupts the phase alignment of subcarriers, which causes constructive interference. From a physical layer view, this means the LED can run at a higher average power without the danger of clipping the signal peaks. This increase in effective signal power improves the BER performance seen in the SNR curves. The BER results shows that the noise floor often linked to non-linear companding was successfully reduced by the precoding stage. The conclusion is that the WHT provides frequency diversity, ensuring that local channel fading or quantization errors do not ruin the entire data packet. Additionally, the system's ability to keep a steep BER decline shows that the hybrid technique is strong against the Additive White Gaussian Noise (AWGN) found indoors. This suggests that SEE-OFDM, when optimized like this, could replace ACO-OFDM in high-bandwidth applications due to its better subcarrier use. [26]-[30] The results also suggest a decrease in the electrical power used by the transmitter, as less power goes to unnecessary signal peaks. This aligns with the goals of green communication, where energy efficiency is just as important as data throughput. Ultimately, moving from high-PAPR signals to a more uniform amplitude distribution improves the overall linearity of the optical front end. These findings support the case for using hybrid signal processing in next-generation VLC standards.

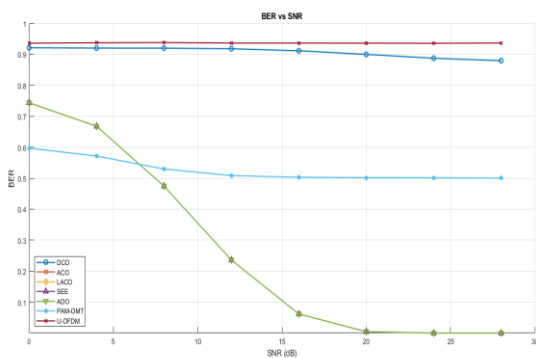

Figure 4. Graphical representation of BER [4]

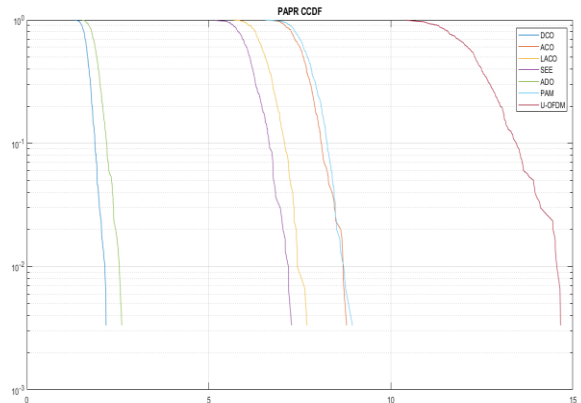

Figure 5 Graphical Representation of PAPR [5]

Conclusion

This research built a hybrid optimization framework for SEE-OFDM systems to reduce the harmful effects of high PAPR and nonlinear LED distortion. By combining Walsh-Hadamard Transform (WHT) precoding with μ -law companding, found a good balance between signal quality and power efficiency. The results clearly show that high PAPR is the main challenge for achieving high-speed, reliable VLC using SEE-OFDM. As detailed in the results section, the baseline system's high peak power causes signal clipping and leads to an unacceptable increase in Bit Error Rate. The above discussion confirmed that without these hybrid solutions, the LED would work in a non-linear state, causing lasting hardware damage and high error rates. The proposed method effectively tackles this issue by lowering the PAPR by 3.5 dB, ensuring the signal stays within the LED's safe linear range. The study shows that the proposed noise cancellation techniques can effectively counteract the potential issues of nonlinear signal compression. [31]-[34] As a result, the spectral efficiency of SEE-OFDM can be fully used without risking the reliability of the communication link. This work offers a scalable route for implementing high-speed VLC in settings with strict lighting and power limits. Future versions of this model could examine adaptive modulation schemes to boost throughput in changing lighting conditions. Adding these techniques to VLC standards would support more robust and energy-efficient indoor wireless



networking. In summary, the combination of precoding and companding is a key improvement for optical OFDM systems. This paper concludes that the hybrid approach is crucial for the commercial success of SEE-OFDM in the 6G era.

References

- [1]. Wang, Z., Mao, T., & Wang, Q. (2017). Optical OFDM for visible light communications. In 2017 13th International Wireless Communications and Mobile Computing Conference (IWCMC) (pp. 1190-1194). IEEE. <https://doi.org/10.1109/IWCMC.2017.7986454>
- [2]. Zhang, X., Babar, Z., Petropoulos, P., Haas, H., & Hanzo, L. (2021). The evolution of optical OFDM. *IEEE Communications Surveys & Tutorials*, 23(3), 1430–1457. <https://doi.org/10.1109/COMST.2021.3065907>
- [3]. Beguni, C., Căilean, A.-M., Avătămăniței, S.-A., & Dimian, M. (2021). Analysis and experimental investigation of the light dimming effect on automotive visible light communications performances. *Sensors*, 21(13), 4446. <https://doi.org/10.3390/s21134446>
- [4]. Ali, M. F., & Jayakody, D. N. K. (2023). SIMO-underwater visible light communication (UVLC) system. *Computer Networks*, 232, 109750. <https://doi.org/10.1016/j.comnet.2023.109750>
- [5]. Zenhom, Y. A., Nasief, M., Mohammed, E., & Mansour, H. (2018). Performance evaluation of EVS audio coder for oriental and orchestral musical. *Engineering Research*, 1, 1–18.
- [6]. Almadani, Y., Plets, D., Bastiaens, S., Joseph, W., Ijaz, M., Ghassemlooy, Z., & Rajbhandari, S. (2020). Visible light communications for industrial applications—Challenges and potentials. *Electronics*.
- [7]. Zenhom, Y. A., Mohammed, E., Mikhael, M. N., & Mansour, H. A. (2019). EVS and OPUS audio coders performance evaluation for oriental and orchestral musical instruments. In *IEEE International Workshop on Multimedia Signal Processing (MMSp)* (pp. 1–6). IEEE.
- [8]. Tariq, F., Khandaker, M. R. A., Wong, K. K., Imran, M. A., Bennis, M., & Debbah, M. (2020). A speculative study on 6G. *IEEE Wireless Communications*, 27(4), 118–125. <https://doi.org/10.1109/MWC.001.1900411>
- [9]. Sobhy, A., ElSayed, S., & Zekry, A. (2020). Enhancing the performance of optical VLC system based on asymmetric symmetric subcarriers OFDM. *International Journal of Communication Systems*, 33(e4385), 1–19. <https://doi.org/10.1002/dac.4385>
- [10]. Zenhom, Y. A., Hamad, E. K. I., & Elnabawy, M. M. (2024). Throughput improvement in ACO-OFDM-based VLC systems using noise cancellation and precoding techniques. Springer, US.
- [11]. Farid, S. M., Saleh, M. Z., Elbadawy, H. M., & Elramly, S. H. (2023). ASCO-OFDM based VLC system throughput improvement using PAPR precoding reduction techniques. *Optical and Quantum Electronics*. <https://doi.org/10.1007/s11082-023-05212-3>
- [12]. Zenhom, Y. A., Hamad, E. K. I., Alghassab, M., & Elnabawy, M. M. (2024). Optical-OFDM VLC system: Peak-to-average power ratio enhancement and performance evaluation. *Sensors*, 24, 2965. <https://doi.org/10.3390/s24082965>
- [13]. Elbakry, M. S., Mohammed, A., & Ismail, T. (2022). Throughput improvement and PAPR reduction for OFDM-based VLC systems using an integrated STC-IMADJS technique. *Optical and Quantum Electronics*, 54(210), 1–17. <https://doi.org/10.1007/s11082-022-04341-0>
- [14]. Mohammed, N. A., Elnabawy, M. M., & Khalaf, A. A. M. (2021). PAPR reduction using a combination between precoding and nonlinear companding techniques for ACO-OFDM-based VLC systems. *Opto-Electronic Review*, 29(1), 59–70. <https://doi.org/10.24425/oer.2021.136121>



- [15]. Khalaf, A. A. M., Elnabawy, M., & Azzam, N. (2023). Non-linear companding techniques with ACO-OFDM-based VLC systems for PAPR reduction. *Journal of Advanced Engineering Trends*, 42, 53–69.
- [16]. Verma, S., Shandilya, A., & Singh, A. (2014). A model for reducing the effect of ambient light source in VLC system. In *IEEE International Advance Computing Conference (IACC)* (pp. 186–188). IEEE. <https://doi.org/10.1109/IACC.2014.6898441>
- [17]. Ahmed, M., Atta, M. A., Farmer, J., Dawy, Z., O'Brien, D., & Bermak, A. (2022). Multidomain suppression of ambient light in visible light communication transceivers. *IEEE Transactions on Intelligent Transportation Systems*, 23(11), 18145–18154. <https://doi.org/10.1109/TITS.2022.318172>
- [18]. Nikkhah, H., Van Acoleyen, K., & Baets, R. (2013). Beam steering for wireless optical links based on an optical phased array in silicon. *Annales des Télécommunications*, 68(1), 57–62. <https://doi.org/10.1007/s12243-012-0284-2>
- [19]. Notaros, J., Notaros, M., Raval, M., & Watts, M. R. (2019). Liquid-crystal-based visible-light integrated optical phased arrays. *Proceedings of the Conference on Lasers and Electro-Optics (CLEO)*, 48, 20–23. https://doi.org/10.1364/CLEO_AT.2019.W1J.5
- [20]. Abdeljabar, S., Eltokhey, M. W., & Alouini, M.-S. (2025). Reconfigurable intelligent surfaces for outdoor visible light communications. *IEEE Internet of Things Magazine*, 8(1), 58–64. <https://doi.org/10.1109/IOTM.2024.3422123>
- [21]. Abuella, H., Elamassie, M., Uysal, M., Xu, Z., Serpedin, E., Qaraqe, K. A., & Ekin, S. (2021). Hybrid RF/VLC systems: A comprehensive survey on network topologies, performance analyses, applications, and future directions. *IEEE Access*, 9, 160402–160436. <https://doi.org/10.1109/ACCESS.2021.3138825>
- [22]. Li, X., Hussain, B., Wang, L., Jiang, J., & Yue, C. P. (2018). Design of a 2.2-mW 24-Mb/s CMOS VLC receiver SoC with ambient light rejection and post-equalization for Li-Fi applications. *Journal of Lightwave Technology*, 36(11), 2366–2375. <https://doi.org/10.1109/JLT.2018.2818668>
- [23]. Griffiths, A. D., Herrnsdorf, J., McKendry, J. J. D., Strain, M. J., & Dawson, M. D. (2020). Gallium nitride micro-light emitting diode structured light sources for multi-modal optical wireless communications systems. *Philosophical Transactions of the Royal Society A: Mathematical, Physical and Engineering Sciences*, 378(2168), 20190320. <https://doi.org/10.1098/rsta.2019.0320>
- [24]. Sobhy, A., ElSayed, S., El-kader Mansour, H. A., Abdelrasoul, M., & Eid, E. M. (2025). Enhancing the performance of NOMA-based VLC systems using an adaptive superimposed constellation algorithm with exact SER analysis. *Optics Communications*.
- [25]. Zhao, N., Yu, R., Jin, M., Yan, Q., & Leung, V. C. M. (2016). Interference alignment and its applications: A survey, research issues, and challenges. *IEEE Communications Surveys & Tutorials*, 18(3), 1779–1803. <https://doi.org/10.1109/COMST.2016.2545718>
- [26]. Kumar, S., & Singh, P. (2024). Joint PAPR and non-linear distortion mitigation in OQAM-FBMC based visible light communication system. *Wireless Personal Communications*, 135, 1617–1634. <https://doi.org/10.1007/s11277-024-10792-4>
- [27]. Hameed, S. M., Sabri, A. A., & Abdulsatar, S. M. (2021). A novel PAPR reduction method for ADO-OFDM VLC systems. *Optical and Quantum Electronics*, 53(230), 1–16. <https://doi.org/10.1007/s11082-021-03075-6>
- [28]. Zenhom, Y. A., Hamad, K. I., & Elnabawy, M. M. (2025). LED nonlinearity mitigation and BER optimization for ACO-OFDM-based VLC systems utilizing nonlinear



- companding and noise mitigation techniques. *Optics and Laser Technology*, 183, 112381. <https://doi.org/10.1016/j.optlastec.2024.112381>
- [29]. Xin, D., Xu, Q., Qiao, S., & Zhang, T. (2019). Non-linear companding transform for DCO-OFDM-based VLC systems. *IET Communications*, 13(8), 1110–1114. <https://doi.org/10.1049/iet-com.2018.7015>
- [30]. Valluri, S. P., Kishore, V., & Vakamulla, V. M. (2020). A new selective mapping scheme for visible light systems. *IEEE Access*, 8, 18087–18096. <https://doi.org/10.1109/ACCESS.2020.2969037>
- [31]. Taha, B., Fayed, H. A., Aly, M. H., & Mahmoud, M. (2022). A reduced PAPR hybrid OFDM visible light communication system. *Optical and Quantum Electronics*, 54, 1–13. <https://doi.org/10.1007/s11082-022-03671-1>
- [32]. Elaage, S., Hmamou, A., El Ghzaoui, M., & Mrani, N. (2024). PAPR reduction techniques optimization based OFDM signal for wireless communication systems. *Telematics and Informatics Reports*, 14, 100137. <https://doi.org/10.1016/j.teler.2024.100137>
- [33]. Niwareeba, R., Cox, M. A., & Cheng, L. (2022). Low complexity hybrid SLM for PAPR mitigation for ACO-OFDM. *ICT Express*, 8(1), 72–76. <https://doi.org/10.1016/j.ict.2021.08.005>
- [34]. Wang, T., Ren, Y., Li, C., & Hou, Y. (2020). A PAPR reduction scheme combining superimposed O-OFDM and μ -law mapping for VLC-OFDM systems. *Optics Communications*, 460, 125190. <https://doi.org/10.1016/j.optcom.2019.125190>